

# CLV-50

## CHECK VALVE / LIFT TYPE

### GENERAL FEATURES

Check valves are commonly used armatures that can be applied for liquids, gases and steam applications. They increase safety and can substitute complicated armatures based on situation.

The working part of the check valves is a hinged disk. This disc can move freely on the hinge pin on one side. It works automatically with fluid motion. When the fluid is flowing in one direction, the disc opens and permits passage. If the flow is reversed, the disc closes. Thus, the flow on the line connecting the check valve is one way.

Ayvaz CLV-50 spring check valves are important for all installations. Check valves are the most important armatures to be taken against water hammer that damage steam installations and armatures.

#### Product Material

Body: GG-25 Cast Iron

Inner Components: AISI 304 Stainless Steel

#### Connection:

Flanged

#### Nominal Diameter:

DN15 (1/2") – DN300 (12")

#### Pressure:

Max. 16 bar

#### Temperature Range

Based on material from -10°C to 180°C

#### Application Areas

- Steam
- Superheated water
- Hot / cold water
- Non-acidic fluids
- Chemical fluids
- Compressed air

# CLV-50 CHECK VALVE / LIFT TYPE

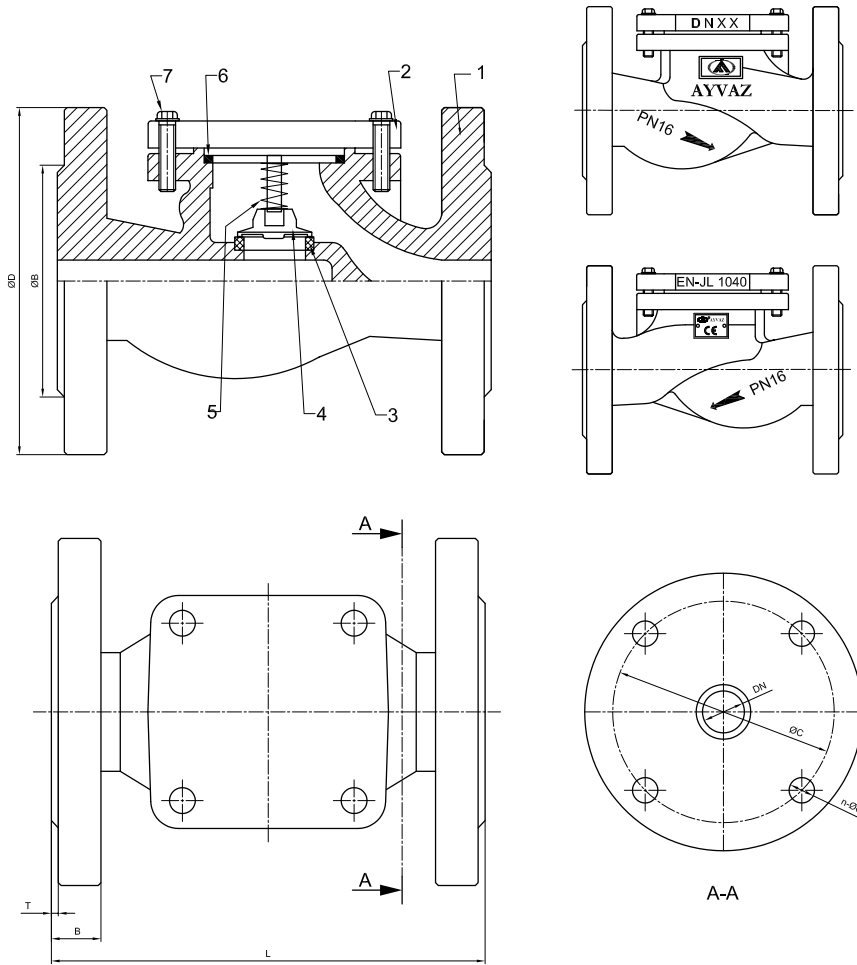

DIMENSIONS							
DN	L ± 1	B + 2	T	ØD ± 1	ØB ± 1	ØC ± 1	n-Ød
15	130	14	2	95	45	65	4-14
20	150	16	2	105	58	75	4-14
25	160	16	2	115	68	85	4-14
32	180	18	2	140	78	100	4-18
40	200	18	2	150	88	110	4-18
50	230	20	3	165	102	125	4-18
65	290	20	3	185	122	145	4-18
80	310	22	3	200	138	160	8-18
100	350	24	3	220	158	180	8-18
125	400	26	3	250	188	210	8-18
150	480	26	3	285	212	240	8-22
200	600	30	3	340	268	295	12-22
250	730	32	4	405	320	355	12-26
300	850	32	4	460	378	410	12-26

PARÇA LİSTESİ		
No	Part Name	Material
1	Body	GG-25 Cast Iron
2	Cover	GG-25 Cast Iron
3	Stainless Steel Ring	AISI 304
4	Disc	AISI 304
5	Spring	AISI 304
6	Rubber Gasket	Cr Ni
7	Nut	Carbon Steel

